



Main Features

- Complies with PICMG1.3 standard
- Intel® Xeon/ Intel® Core™ i7/i5/i3 LGA1151 processor with 100 Series chipset
- Up to 32 GB of dual-channel DDR4 1866/2133 MHz
- PCIe 3.0, USB 3.0, SATA 3.0, and SW Raid 0, 1, 5, 10
- Supports triple display
- Supports TPM modules
- Multiple PCIe Gen3 Lanes , up to 30 port PCIe lanes

Note :

Intel 7th generation processors only support Windows 10 (64-bit).

Product Overview

The PIC 688H is a PICMG1.3 Half-size Single-Board Computing .It equipped with Intel® 6th /7th generation Core™ i7/i5/i3 processors and Intel® H110 chipset. It comes with Dual DDR4 DIMM socket up to 32GB DDR4 1866/2133/2666 MHz and integrated HD Graphic controller.

Specifications

CPU Support

- 6th/7th generation Intel® Xeon and Intel® Core™ i7/i5/i3 processor (65W/35W) TDPs, Socket LGA1151

Main Memory

- 2 x SODIMM, support Dual channel DDR4 SODIMM 1866/2133/2666 MT/S (Maximum 32GB)

Platform Control Hub

- Intel®H170 Express Chipset PCH

Display

Support independent triple display

- DVI-I(VGA): Resolution up to 1920*1200 pixels @60MHz
- DVI-D(HDMI): Resolution up to 4096*2304 pixels @60MHz
- DP: Resolution up to 4096*2304 pixels @60MHz

On board LAN

- 1 x Intel®WG1219LM GbE PHY
- 1 x Intel®I211 Gigabit Ethernet Controller
- Support Boot from LAN (PXE)
- Support Wake on LAN

Front I/O

- USB3.0 *2 port
- RJ45*2 port
- DVI-I *1 port

On board I/O

- 4 x SATA port Support RAID 0/1/5/10
- DP port with 20pin Connector

SIO: ITE8786

- COM 1, 2, Support RS232 with single mini type connector, support 5V. (refer to pin define)
- COM3, 4 support switchable RS232/422/485
- PS2 KB/MS *1 JST connector
- 4 Ports USB2.0
- 1 x DIO (8 in , 8 out)
- 1 x Smart FAN connector for CPU

Environment

- Board level operating temperatures: -20°C to 60°C
- Storage temperatures: -20°C to 85°C

Relative humidity:

- 0% to 90% (operating, non-condensing)
- 0% to 95% (non-operating, non-condensing)

Certifications

- CE approval
- FCC Class A

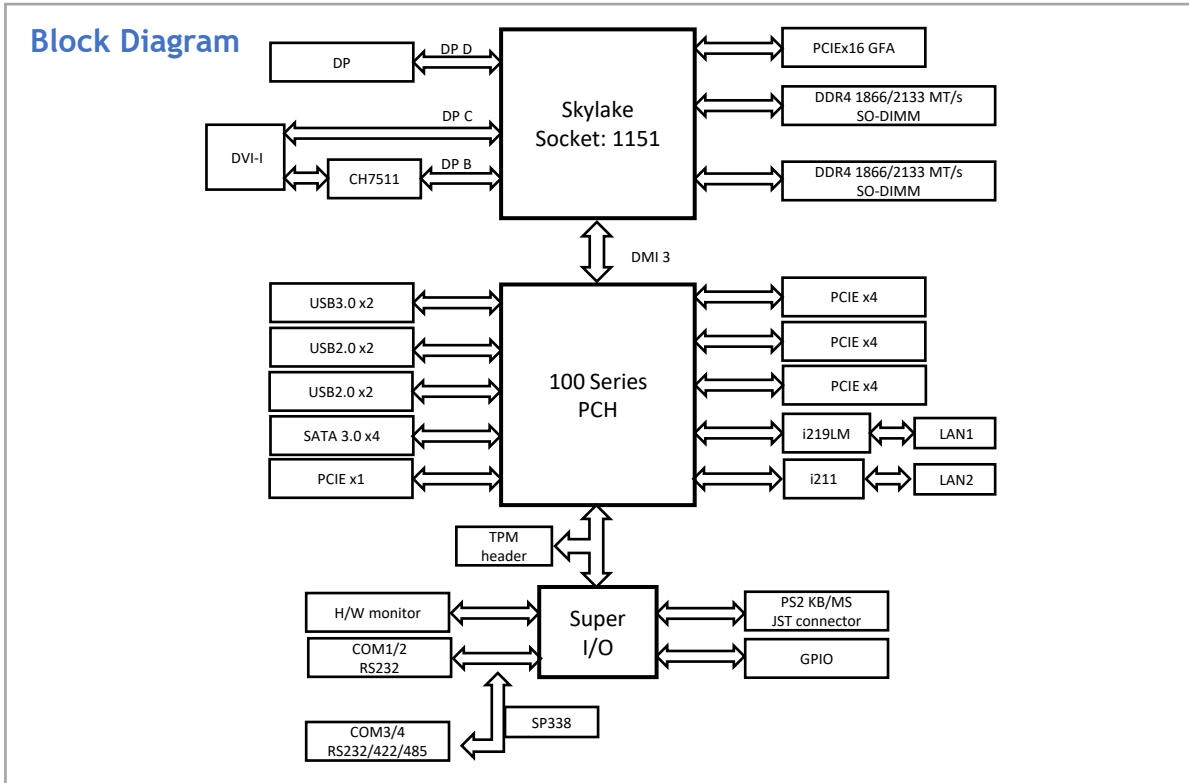

Top Side Dimensions

- 208mm x 126mm, (Dual side)

Power Requirements

- Power source from backplane through golden finger and AUX +12V
- Support ATX/AT function by jumper setting
- BIOS default is (ATX MODE)

Operating System

- Windows® 7
- Windows® 10

Backplane Selection Guide

	NBP1468	NBP1465	NBP1037	NBP1052	NBP06P2	NBP06E5	NBP05P2	NBP1024	NBP1257
PIC688-H	*	*	*	*	*	*	*	Support	Support
slot	PCIex 16	1	1	1	2	1	1	2	1
	PCIe x 8		1	1	1		1		
	PCIe x 4	5	3	3	3	2	2	1	1
	PCIe x 1	1	1	2			1		4
	PCI	4	5		2	2		2	4